

# DSIAC TECHNICAL INQUIRY (TI) RESPONSE REPORT

## The Availability of Mechanisms to Protect Crews Against Gun Tube Rupture

### Report Number:

DSIAC-2020-1321

Completed July 2020

**DSIAC** is a Department of Defense  
Information Analysis Center

### MAIN OFFICE

4695 Millennium Drive  
Belcamp, MD 21017-1505  
443-360-4600

### REPORT PREPARED BY:

Author Names: Richard Piner and Doyle Motes  
Office: Texas Research Institute Austin, Inc.

Information contained in this report does not constitute endorsement by the United States Department of Defense of any non-federal entity or technology sponsored by a non-federal entity.

DSIAC is a DoD Information Analysis Center (IAC) sponsored by the Defense Technical Information Center (DTIC) with policy oversight provided by the Office of the Under Secretary of Defense (OUSD) for Research and Engineering (R&E). DSIAC is operated by the SURVICE Engineering Company.

| <b>REPORT DOCUMENTATION PAGE</b>  |                         |  | <i>Form Approved</i><br><i>OMB No. 0704-0188</i>                 |                                      |
|---|-------------------------|--|--|--------------------------------------|
| Public reporting burden for this collection of information is estimated to average 1 hour per response, including the time for reviewing instructions, searching existing data sources, gathering, and maintaining the data needed, and completing and reviewing this collection of information. Send comments regarding this burden estimate or any other aspect of this collection of information, including suggestions for reducing this burden to Department of Defense, Washington Headquarters Services, Directorate for Information Operations and Reports (0704-0188), 1215 Jefferson Davis Highway, Suite 1204, Arlington, VA 22202-4302. Respondents should be aware that notwithstanding any other provision of law, no person shall be subject to any penalty for failing to comply with a collection of information if it does not display a currently valid OMB control number. <b>PLEASE DO NOT RETURN YOUR FORM TO THE ABOVE ADDRESS.</b>                                |                         |  |  |                                      |
| <b>1. REPORT DATE (DD-MM-YYYY)</b><br>07-07-2020  |                         | <b>2. REPORT TYPE</b><br>Technical Research Report |  | <b>3. DATES COVERED (From - To)</b>  |
| <b>4. TITLE AND SUBTITLE</b><br><br>The Availability of Mechanisms to Protect Crews Against Gun Tube Rupture  |                         |  | <b>5a. CONTRACT NUMBER</b><br>FA8075-14-D-0001                   |                                      |
|   |                         |  | <b>5b. GRANT NUMBER</b>  |                                      |
|   |                         |  | <b>5c. PROGRAM ELEMENT NUMBER</b>                                |                                      |
|   |                         |  | <b>5d. PROJECT NUMBER</b>  |                                      |
|   |                         |  | <b>5e. TASK NUMBER</b>   |                                      |
| <b>6. AUTHOR(S)</b><br>Richard Piner and Doyle Motes  |                         |  | <b>5f. WORK UNIT NUMBER</b>                                      |                                      |
| <b>7. PERFORMING ORGANIZATION NAME(S) AND ADDRESS(ES)</b><br>Defense Systems Information Analysis Center (DSIAC)<br>Texas Research Institute Austin, Inc.<br>415 Crystal Creek Drive<br>Austin, TX 78746  |                         |  | <b>8. PERFORMING ORGANIZATION REPORT NUMBER</b>                  |                                      |
| <b>9. SPONSORING / MONITORING AGENCY NAME(S) AND ADDRESS(ES)</b><br>Defense Technical Information Center (DTIC)<br>8725 John J. Kingman Rd.<br>Ft. Belvoir, VA 22060-6218   |                         |  | <b>10. SPONSOR/MONITOR'S ACRONYM(S)</b>                          |                                      |
|   |                         |  | <b>11. SPONSOR/MONITOR'S REPORT NUMBER(S)</b>                    |                                      |
| <b>12. DISTRIBUTION / AVAILABILITY STATEMENT</b><br><br>Approved for public release: distribution unlimited.  |                         |  |  |                                      |
| <b>13. SUPPLEMENTARY NOTES</b><br>Materials and Manufacturing Processes: Materials/Processes for Survivability and Life Extension; Advanced Materials, Weapon Systems   |                         |  |  |                                      |
| <b>14. ABSTRACT</b><br>The Defense Systems Information Analysis Center received a technical inquiry on protecting crews from gun tube rupture. In particular, there is a possibility that a 120-mm mortar tube could rupture due to inclusions present in the microstructure of the steel used to construct the gun tube. This rupture would release a high-temperature gas flow at 19,000 psi if the failure is a ductile fracture. If the failure is a brittle fracture, pieces of steel would also be released. The inquiring organization is looking for possible solutions to protect the crew in case of this event, without limiting the weapon's usage. Materials engineering and ballistics subject matter experts at the Texas Research Institute Austin, Inc., performed literature searches using the Defense Technical Information Center, open sources, and university libraries to identify related work and provided information on potential complementary technologies. |                         |  |  |                                      |
| <b>15. subject terms</b><br>mortar, gun tube, composite, inclusion  |                         |  |  |                                      |
| <b>16. SECURITY CLASSIFICATION OF:</b> U  |                         |  | <b>17. LIMITATION OF ABSTRACT</b><br><br>UU                      | <b>18. NUMBER OF PAGES</b><br><br>10 |
| <b>a. REPORT</b><br>U   | <b>b. ABSTRACT</b><br>U | <b>c. THIS PAGE</b><br>U                           |  |                                      |
|   |                         |  | <b>19b. TELEPHONE NUMBER (include area code)</b><br>443-360-4600 |                                      |

## ABOUT DTIC AND DSIAC

The Defense Technical Information Center (DTIC) collects, disseminates, and analyzes scientific and technical information to rapidly and reliably deliver knowledge that propels development of the next generation of Warfighter technologies. DTIC amplifies the U.S. Department of Defense's (DoD's) multibillion dollar annual investment in science and technology by collecting information and enhancing the digital search, analysis, and collaboration tools that make information widely available to decision makers, researchers, engineers, and scientists across the Department.

DTIC sponsors the DoD Information Analysis Center's (IAC's) program, which provides critical, flexible, and cutting-edge research and analysis to produce relevant and reusable scientific and technical information for acquisition program managers, DoD laboratories, Program Executive Offices, and Combatant Commands. The IACs are staffed by, or have access to, hundreds of scientists, engineers, and information specialists who provide research and analysis to customers with diverse, complex, and challenging requirements.

The Defense Systems Information Analysis Center (DSIAC) is a DoD IAC sponsored by DTIC to provide expertise in nine technical focus areas: weapons systems; survivability and vulnerability; reliability, maintainability, quality, supportability, and interoperability; advanced materials; military sensing; autonomous systems; energetics; directed energy; and non-lethal weapons. DSIAC is operated by SURVICE Engineering Company under contract FA8075-14-D-0001.

A chief service of the DoD IACs is free technical inquiry (TI) research, limited to 4 research hours per inquiry. This TI response report summarizes the research findings of one such inquiry jointly conducted by DSIAC.

## ABSTRACT

The Defense Systems Information Analysis Center received a technical inquiry on protecting crews from gun tube rupture. In particular, there is a possibility that a 120-mm mortar tube could rupture due to inclusions present in the microstructure of the steel used to construct the gun tube. This rupture would release a high-temperature gas flow at 19,000 psi if the failure is a ductile fracture. If the failure is a brittle fracture, pieces of steel would also be released. The inquiring organization is looking for possible solutions to protect the crew in case of this event, without limiting the weapon's usage. Materials engineering and ballistics subject matter experts at the Texas Research Institute Austin, Inc., performed literature searches using the Defense Technical Information Center, open sources, and university libraries to identify related work and provided information on potential complementary technologies.

# Contents

**ABOUT DTIC AND DSIAC..... i**

**ABSTRACT ..... ii**

**1.0 TI Request ..... 1**

    1.1 INQUIRY ..... 1

    1.2 DESCRIPTION ..... 1

**2.0 TI Response ..... 1**

    2.1 EXISTING SOLUTIONS..... 1

    2.2 NEW TECHNOLOGIES ..... 1

**REFERENCES..... 4**

**BIOGRAPHIES..... 5**

# List of Figures

Figure 1: Composite Overwrapped 120-mm Gun Tube Images [4] (*Source: Google Patents*) ..... 2

Figure 2: A Casing From an Altair Rocket Stage, Essentially a Composite Overwrapped Pressure Vessel (*Source: Smithsonian National Air and Space Museum*) ..... 2

## 1.0 TI Request

### 1.1 INQUIRY

Are there existing solutions to protect a gun crew in case of barrel failure initiating from an inclusion without limiting the weapon's usage?

### 1.2 DESCRIPTION

There is a possibility that a 120-mm mortar tube could rupture due to inclusions present in the microstructure of the steel used to construct the gun tube. This rupture would release a high-temperature gas flow at 19,000 psi if the failure is a ductile fracture. If the failure is a brittle fracture, pieces of steel would also be released. The inquiring organization is looking for possible solutions to protect the crew in case of this event, without limiting the weapon's usage.

## 2.0 TI Response

### 2.1 EXISTING SOLUTIONS

There is little information on this in the available literature. Most solutions that would provide true protection against either a ductile failure (gas escape) or brittle failure (gas escape with shrapnel) involve systems that would severely restrict the gun's usage (additional layers of steel to provide more protection, similarly to the laminated structure of large-caliber weapons, or other steel tubes surrounding the barrel acting as a shield but not in direct contact with the barrel).

Several publicly available patents were identified [1–5]. Of these, U.S. Patent 9,863,732 [4] seems to provide the most relevant solution. Additionally, U.S. Patent 7,963,202 [5] has a long list of prior art relevant to this topic.

### 2.2 NEW TECHNOLOGIES

Development of new materials and methods seem to be ongoing, even though the basic idea is the same as weapons used late in World War I. Mortar tubes made solely from steel are viable candidates for replacement with modern materials, although this can be a challenge given procurement procedures.

Developing composite overwrapped pressure vessels using carbon fiber reinforced polymer, the same material class used to construct modern airframes, offers a means to retrofit existing gun tubes. This is alluded to in U.S. Patent 9,863,732 (see Figures 1 and 2 for examples).

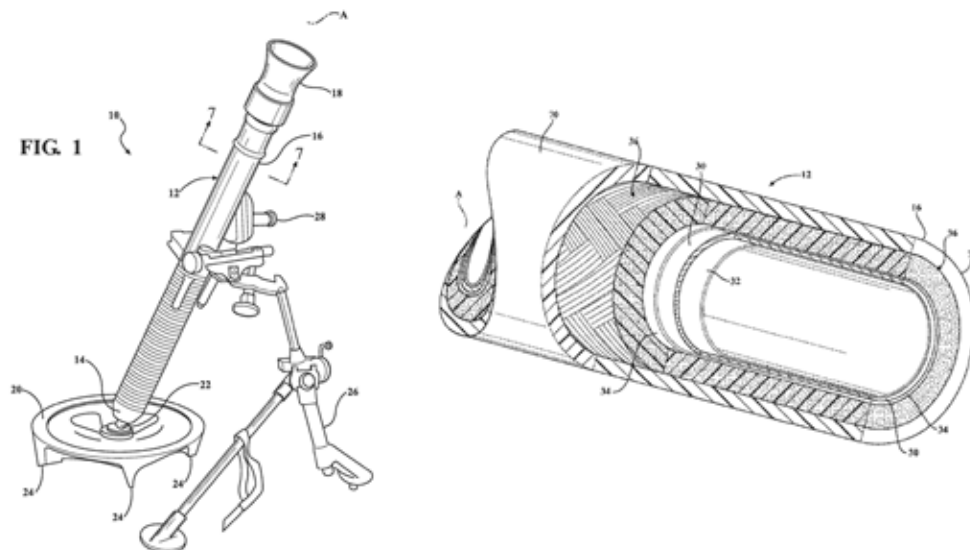

Figure 1: Composite Overwrapped 120-mm Gun Tube Images [4] (Source: Google Patents).



Figure 2: A Casing From an Altair Rocket Stage, Essentially a Composite Overwrapped Pressure Vessel (Source: Smithsonian National Air and Space Museum).

A U.S. Army report describes trying to shift to titanium (Ti) alloys [6–8] to leverage the lightweight nature of the material but specifically states that a suitable momentum trap needs to be devised before this would be possible (as well as mitigating internal damage due to erosion). This report also mentions developing a metal matrix composite as a jacketing material but mentioned how no data were available on fatigue, thermal fatigue, and high-temperature fatigue (no reference to this program was provided). In addition, other work

discussed the possibility that the steel projectile may gall the Ti barrel during firing [9]. The report discusses switching materials to an Ni 718 alloy to gain resistant against failure at high temperatures. This does provide a way past dealing with inclusions in steel but will require methods to address different types of inclusions that appear in Ni-based superalloys (also note that Ni-based superalloys are slightly heavier than steel alloys).

Another possible avenue is nondestructive inspection/evaluation (NDI/E) of the barrels during maintenance intervals for the mortars. Beginning in 2014, U.S. Army Watervliet Arsenal, NY, has invested \$26M in upgrades that included a pair of ultrasonic immersion tanks for inspecting newly fabricated mortar tubes of various calibers [10]. However, these are done post-manufacture and not as part of any regular maintenance. The U.S. Air Force routinely performs maintenance on different parts of different aircraft depending on the specific usage and part of the structure. A system similar to this may provide the safety increase that the Army desires but in another way. From a technology transfer perspective, many NDI/E techniques from the oil and gas industry may be utilized for rapid, in-field gun tube inspections. The oil and gas industry have to constantly inspect pipelines (composed of steel and, in some cases, composite). A number of existing ultrasonic, eddy current, and magnetic flux linkage (MFL) solutions may already exist for this problem (both sensors, arrays, and crawlers [for external inspections]) and pigs [for internal inspections, a process known as pigging]).

Following the technology that the U.S. Army uses for enhanced small arms protection insert body armor, it may be possible to layer ultrahigh molecular weight polyethylene layers on the outside of the barrel (depending on heating constraints). A "lower tech" version of this may also be available via using sandbags (or a modified variant thereof). Both these methods can provide some protection in a dynamic impact scenario, but it is unknown if the same degree of protection would be conferred for a material directly layered onto the steel barrel (where the damage would occur similarly to a spallation event, with the shock passing through the different material layers and thusly attenuated).



## REFERENCES

- [1] Varlas, M. "Method of Making High Modulus Graphite Fiber Reinforced Tubes." U.S. Patent 3,879,244, U.S. Air Force, <https://patents.google.com/patent/US3879244A/en?q=U.S.+Patent+3.879%2c244>, 22 April 1975.
- [2] Briggs, V. R. "Composite Firearm Barrel Reinforcement." U.S. Patent 7,921,590, Sturm Ruger and Co Inc., <https://patents.google.com/patent/US7921590B2/en?q=U.S.+Patent+7%2c921%2c590>, 12 April 2011.
- [3] Mulligan, C. P., A. Littlefield, and J. Root. "Multi-layered Mortar Tube." U.S. Patent 9,939,222, U.S. Secretary of Army, <https://patents.google.com/patent/US9939222B1/en?q=U.S.+Patent+9%2c939%2c222>, 10 April 2018.
- [4] Curliss, D. B., and J. E. Lincoln. "Lightweight Composite Mortar Tube." U.S. Patent 9,863,732, Proof Research, Inc., <https://patents.google.com/patent/US9863732B2/en?q=+U.S.+Patent+9%2c863%2c732>, 15 September 2016.
- [5] Becker, R. F., M. D. Witherell, J. Santiago, G. E. Hathaway, IV, R. Espinosa, and S. Tauscher. "Superalloy Mortar Tube." U.S. Patent 7,963,202, U.S. Secretary of Army, <https://patents.google.com/patent/US7963202B1/en>, 21 June 2011.
- [6] Burke, J. J. "Historical Monograph: Ordnance Corps Titanium Program 1946-61." Watertown Arsenal Monograph MS-39, Watertown, MA, 1962.
- [7] Montgomery, R. S. "Wear of Titanium Alloy in Mortar Tubes and Effect of Anodizing (Declassified)." Watervliet Arsenal Technical Report WVT-7013, Watervliet, NY, 1 June 1970.
- [8] Fonte, M. "Flowforming Mortar Cannon Barrels." *Advanced Materials & Processes*, vol. 166, no. 5, [https://www.asminternational.org/news/magazines/-/journal\\_content/56/10192/AMP16605P047/PERIODICAL-ARTICLE](https://www.asminternational.org/news/magazines/-/journal_content/56/10192/AMP16605P047/PERIODICAL-ARTICLE), 1 May 2008.
- [9] Montgomery, J. S., and R. L. Ellis. "Large Caliber Gun Tube Materials Systems Design." *10<sup>th</sup> U.S. Army Gun Dynamics Symposium Proceedings*, Austin, TX, Distribution A, DTIC Accession Number: ADP012479, <https://apps.dtic.mil/sti/pdfs/ADP012479.pdf>, 23–26 April 2001.
- [10] Snyder, J. B. "Army Manufacturer Seeks to Raise its Quality, Confidence of Infantrymen." U.S. Army Watervliet Arsenal Public Affairs, [https://www.army.mil/article/122279/army\\_manufacturer\\_seeks\\_to\\_raise\\_its\\_quality\\_confidence\\_of\\_infantrymen](https://www.army.mil/article/122279/army_manufacturer_seeks_to_raise_its_quality_confidence_of_infantrymen), 1 April 2014.

## BIOGRAPHIES

**Richard Piner** currently serves in the Mechanical Engineering Department at the University of Texas at Austin. He has over 48 years of industry experience spanning a wide variety of technical topics, including, but not limited to, the four broad categories of reactors, graphene, graphene oxide, and scanning technique. He has hundreds of scholarly publications yielding over 40,000 citations to his work. Dr. Piner holds a Ph.D. in physics from Purdue, where he studied scanning tunneling microscopy.

**Doyle Motes** is a licensed professional engineer in Texas and is employed as a research engineer at TRI Austin, Inc. He has extensive experience and has published in the fields of pulsed power, materials engineering and processing, and nondestructive testing. His research interests include additive manufacturing and three-dimensional printing, materials engineering and processing, nondestructive testing (in particular, ultrasound and eddy current testing), sustainment of aging weapon systems, automation of inspection/validation technologies, and materials state sensing. Mr. Motes holds bachelor's and master's degrees in mechanical engineering from the University of Texas at Austin.